

ACTUATOR SIZE	J	L	M	N	P	Q	R	NUMBER OF TURNS
MDT-2S	4-11/16	2	2-1/8	2	4-1/2	4-1/4	8-1/4	32
MDT-3S	5-5/8	2-7/16	3-1/4	3-5/32	5-5/8	5-3/8	10-3/8	30
MDT-4S	6-3/8	3-7/16	3-3/8	4	7-5/16	6-3/4	11-5/16	40
MDT-5	7-9/16	3-1/2	4-1/2	5-1/2	8-3/4	10-7/16	17	44
MDT-5S	8-5/16	3-15/16	5-5/8	7	10-5/8	15-15/16	19-7/8	136
MDT-6S	11-1/8	5-1/16	7	8-1/4	12-5/8	18-5/8	26-1/2	215

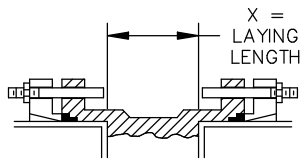

INSTALLATION DIAGRAM
BOLTS, NUTS, GLANDS
AND GASKETS FURNISHED
BY OTHERS

VALVE SIZE	A	B	C	D	E	F	G	X
24	18-5/8	18-5/8	31-9/16	13-1/4	1-5/8	16--3/4	30	6-3/8
30	21-1/2	24-3/8	39	18	1-13/16	20--1	36-7/8	10
36	25-7/16	28-1/4	45-7/8	22	2	24--1	43-3/4	14
42	29-7/8	32-7/8	53	22	2	28--1-1/4	50-5/8	14
48	34-1/16	37-1/8	59-7/8	24	2	32--1-1/4	57-1/2	16

3-1/2 SPACE REQUIRED
FOR THRUST BEARING
COVER REMOVAL

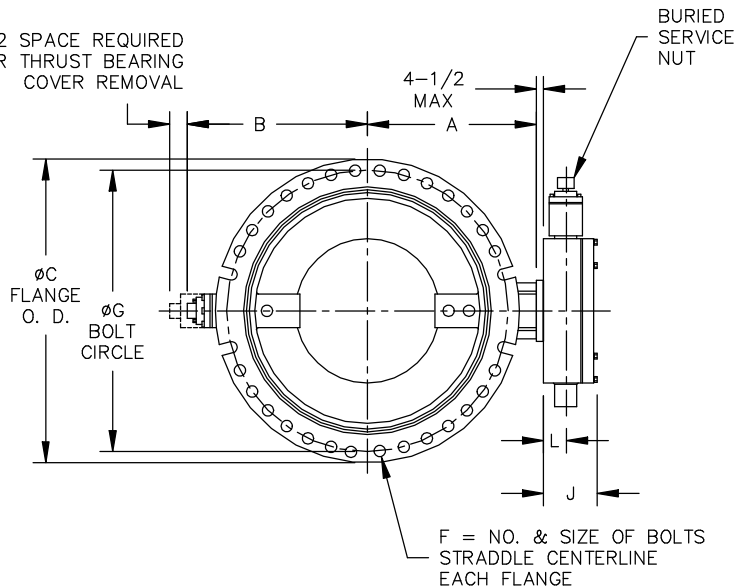

SPUR GEAR FURNISHED
ON MDT-6S

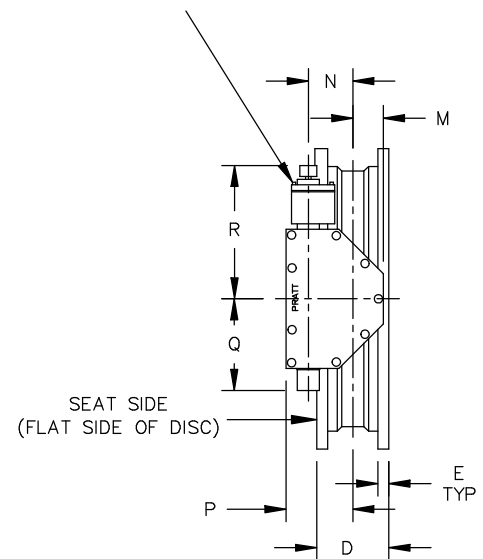

ACTUATOR POSITION 1

NOTES:

1. ALL DIMENSIONS SHOWN IN INCHES. "D" DIMENSION $\pm 1/8$ " BOLT HOLES WILL BE $1/8$ " LARGER THAN DIAMETER OF BOLT
2. DIMENSIONS AND DRILLING OF MECHANICAL JOINT ENDS CONFORM TO ANSI AWWA C111 A21.11.
3. CAUTION:
IT IS RECOMMENDED THAT VALVES BE INSTALLED INTO THE PIPING SYSTEM IN ACCORDANCE WITH AWWA M-11 IN ORDER TO PREVENT ANY UNDUE PIPING STRESS, DEFLECTION OR BENDING THAT MAY EFFECT THE PERFORMANCE OF THE VALVE.

4. VALVES MANUFACTURED AND TESTED IN ACCORDANCE WITH AWWA SPECIFICATION C-504 LATEST REVISION, CLASS 150B.

REV	DATE	BY	DESCRIPTION	APP.
△	10-10-06	CEG	CORRECTED "J" DIM.	
△	4-5-05	ES	CORRECTED NOTE 4	JR

PRATT HENRY PRATT COMPANY
AURORA, ILL.

TRITON XR70 MJE
24 INCH THRU 48 INCH
MDT W/BSN

SCALE NONE DATE 12/07/04

DRAWN BY_BZ CHECKED BY_ES

APPROVED GA=BORDER

DRWG. NO. GA-11301 REV 2 A/C