

MATERIAL OPTIONS AS CHECKED

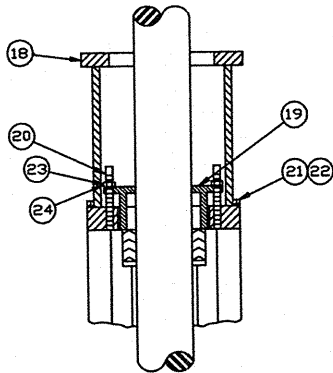

OPTIONAL
REPLACEABLE PACKING BONNET
ASSEMBLY

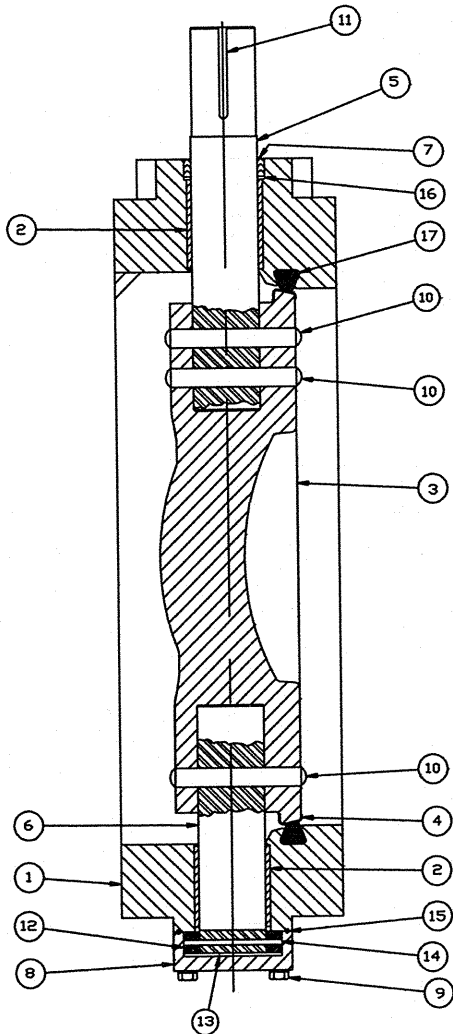

ITEM NO.	DESCRIPTION	MATERIALS	
1	BODY	CAST IRON ASTM A-126 CLASS B DUCTILE IRON ASTM A-536 (65-45-12)	✓
2	BEARINGS	TEFLON LINED, FIBERGLASS BACKED	
3	DISC	DUCTILE IRON ASTM A-536 (65-45-12)	△ 1
4	DISC EDGE	STAINLESS STEEL TYPE 316	△
5	TOP STUB SHAFT	STAINLESS STEEL ASTM A-276 TYPE 304 STAINLESS STEEL ASTM A-276 TYPE 316 STN. STL. A-564 TYPE 630 COND. H-1150 MONEL ASTM B-164 ALLOY 400	△ 3
6	BOTTOM STUB SHAFT	STAINLESS STEEL ASTM A-276 TYPE 304 STAINLESS STEEL ASTM A-276 TYPE 316 STN. STL. A-564 TYPE 630 COND. H-1150 MONEL ASTM B-164 ALLOY 400	△ 3
7	PACKING	RUBBER (BUNA-N) RESILOSEAL W (EPDM)	
8	BOTTOM COVER	CAST IRON ASTM A-126 CLASS B	
9	CAP SCREWS	CARBON STEEL STAINLESS STEEL TYPE 304 STAINLESS STEEL TYPE 316	
10	SQUEEZE PINS	STAINLESS STEEL ASTM A-276 TYPE 304 STAINLESS STEEL ASTM A-276 TYPE 316 STN. STL. A-564 TYPE 630 COND. H-1150 MONEL ASTM B-164 ALLOY 400	△ 3
11	KEY	CARBON STEEL AISI 1045	
12	THRUST COLLAR	BRONZE ASTM B-505 ALLOY C93200	
13	THRUST COLLAR SHIMS	BRASS ALLOY C26000 HALF HARD (H02)	
14	SPRING PIN	STAINLESS STEEL TYPE 420	
15	O-RING	RUBBER (BUNA N)	
16	PACKING RETAINER	NYLON	
17	SEAT	RESILOSEAL R (BUNA-N) RESILOSEAL W (EPDM)	
18	BONNET	CAST IRON ASTM A-48 CLASS 40	
19	PACKING GLAND	BRONZE ASTM B-584 ALLOY C86400	
20	PACKING GLAND STUD	STAINLESS STEEL TYPE 304	
21	CAP SCREWS	CARBON STEEL	
22	LOCKWASHERS	CARBON STEEL	
23	PACKING GLAND NUT	STAINLESS STEEL TYPE 304	
24	LOCTITE	GRADE CV	

△	7-15-11	JTC	UPDATED MATERIAL	RCB
△	1-5-11	CEM	ADD MATERIAL OPTION	RCB
△	7-19-06	RCB	DELETED C.I. OPTION	PPS
△	4-8-06	CEG	ADDED DUCTILE OPTION	JR
REV	DATE	BY	DESCRIPTION	APP
PRATT HENRY PRATT COMPANY AURORA, ILL.				
CROSS SECTION PARTS AND MATERIAL LIST 24" TRITON-XR BUTTERFLY VALVE				
SCALE	NONE	DATE	2-04-05	
DRAWN BY	AAT	CHECKED BY	ES	
APPROVED		GA=BORDER		
DRWG. NO.	GA-11337	REV	4	A/C